

LIF

Metallverschraubung
gerade
Außengewinde

Metal connector
straight
outer thread

IP 40
-40°C ... +250°C

KONSTRUKTION

Rundes Verschraubungsgehäuse
mit Sechskantschlüsselfläche,
feststehendes Außengewinde metrisch
nach EN 60423 oder PG nach DIN 40430

STRUCTURE

Round connector body
hexagonal wrench surface
fixed outer thread metric acc. to
EN 60423 or PG acc. to DIN 40430

MATERIAL

Gehäuse Messing vernickelt
Abdeckhülse Messing vernickelt

MATERIAL

Connector body nickel-plated brass
Cover sleeve nickel-plated brass

EIGENSCHAFTEN

- integrierte Schlauchdrehsperr
- Abdeckung der Schlauchenden
- vibrations- und zugfest

PROPERTIES

- integrated conduit screw out
- covering of the conduit ends
- vibrationproof and tensionproof

MONTAGE

Abdeckhülse auf das Schlauchende
stecken und danach das Verschraubungs-
gehäuse eindrehen

ASSEMBLY

Push the cover sleeve on the end of the
conduit and screw the connector body in
the conduit



IBIS

ELECTRO-PRODUCTS CORP.

AD
OD



FLEXA No.



FLEXA No.



LIF-M

Kleine VPE
small packing unit

| ø | Metr. EN 60423 | [IP 40] | øI mm | øB mm | C mm | D mm | SW mm | kg 100 pcs. | St. pcs. | St. pcs. |
|----|-------------------|----------------|----------|----------|---------|---------|----------|----------------|-------------|-------------------|
| 10 | M 12 x 1,5 | 1 5801 310 012 | 5,9 | 16,0 | 10,0 | 26,0 | 15 | 1,550 | 50 | 1 5801 810 012 10 |
| 14 | M 16 x 1,5 | 1 5801 314 016 | 8,9 | 21,0 | 10,0 | 27,0 | 19 | 2,400 | 50 | 1 5801 814 016 10 |
| 17 | M 16 x 1,5 | 1 5801 317 016 | 11,0 | 25,0 | 10,0 | 27,0 | 23 | 3,000 | 50 | 1 5801 817 016 10 |
| 17 | M 20 x 1,5 | 1 5801 317 020 | 12,0 | 25,0 | 10,0 | 27,0 | 23 | 2,900 | 50 | 1 5801 817 020 10 |
| 21 | M 20 x 1,5 | 1 5801 321 020 | 15,0 | 29,0 | 10,0 | 27,0 | 27 | 3,800 | 50 | 1 5801 821 020 10 |
| 27 | M 25 x 1,5 | 1 5801 327 025 | 20,0 | 37,0 | 11,0 | 30,5 | 34 | 6,300 | 25 | 1 5801 827 025 10 |
| 36 | M 32 x 1,5 | 1 5801 336 032 | 27,5 | 45,6 | 13,0 | 33,0 | 43 | 8,100 | 25 | 1 5801 836 032 2 |
| 45 | M 40 x 1,5 | 1 5801 345 040 | 35,0 | 59,0 | 13,0 | 33,0 | 54 | 13,300 | 25 | 1 5801 845 040 2 |
| 56 | M 50 x 1,5 | 1 5801 356 050 | 45,0 | 69,0 | 14,0 | 34,0 | 66 | 18,500 | 10 | 1 5801 856 050 2 |

LIF-P

Kleine VPE
small packing unit

| ø | PG DIN 40430 | [IP 40] | øI mm | øB mm | C mm | D mm | SW mm | kg 100 pcs. | St. pcs. | St. pcs. |
|----|-----------------|----------------|----------|----------|---------|---------|----------|----------------|-------------|-------------------|
| 10 | 7 | 1 5801 010 007 | 5,9 | 16,0 | 10,0 | 26,0 | 15 | 1,600 | 50 | 1 5801 410 007 10 |
| 14 | 9 | 1 5801 014 009 | 8,9 | 21,0 | 10,0 | 27,0 | 19 | 2,400 | 50 | 1 5801 414 009 10 |
| 17 | 11 | 1 5801 017 011 | 12,0 | 25,0 | 10,0 | 27,0 | 23 | 3,100 | 50 | 1 5801 417 011 10 |
| 19 | 13,5 | 1 5801 019 013 | 14,0 | 27,0 | 10,0 | 27,0 | 25 | 3,200 | 50 | 1 5801 419 013 10 |
| 21 | 16 | 1 5801 021 016 | 15,9 | 29,0 | 10,0 | 27,0 | 27 | 3,900 | 50 | 1 5801 421 016 10 |
| 27 | 21 | 1 5801 027 021 | 20,4 | 37,0 | 11,0 | 30,6 | 34 | 6,200 | 25 | 1 5801 427 021 10 |
| 36 | 29 | 1 5801 036 029 | 27,5 | 45,6 | 13,0 | 33,0 | 43 | 8,800 | 25 | 1 5801 436 029 2 |
| 45 | 36 | 1 5801 045 036 | 36,6 | 59,0 | 13,0 | 33,0 | 54 | 11,750 | 25 | 1 5801 445 036 2 |
| 56 | 48 | 1 5801 056 048 | 47,5 | 69,0 | 13,5 | 33,5 | 66 | 16,400 | 10 | 1 5801 456 048 2 |

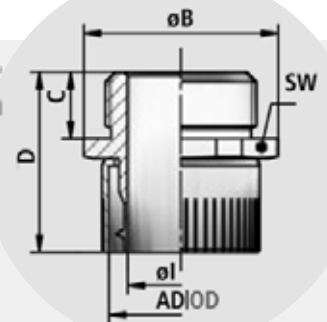

A Verschraubungsgehäuse
connector body
B Abdeckhülse
cover sleeve